

# BF 150.10

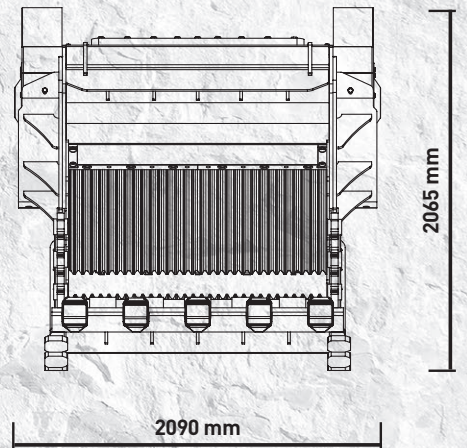

# “The records bucket”

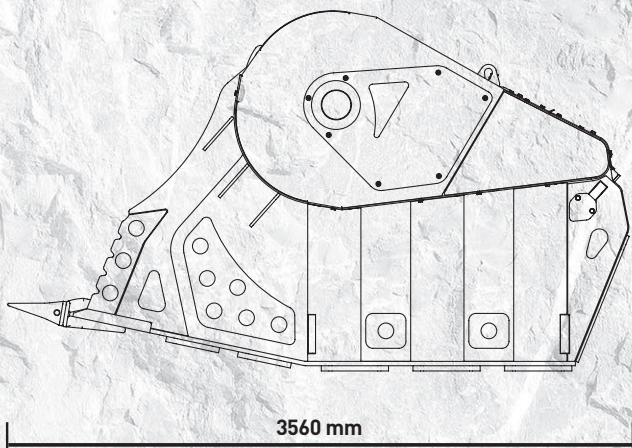
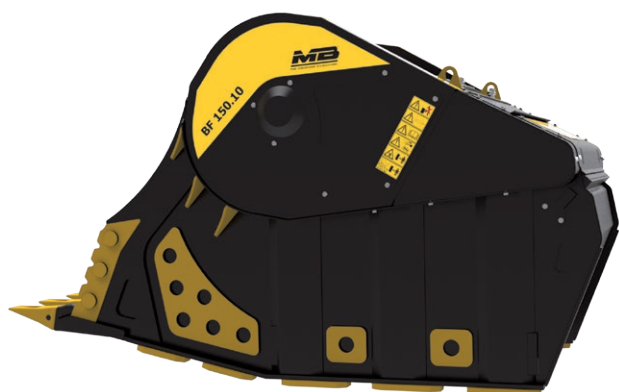

Unique in its kind in size and performance, the BF 150.10 is the largest crusher bucket in the world. Designed for excavators exceeding 70 Ton and ideal for applications in quarry, mining, and general crushing on large job sites. The BF 150.10 crusher bucket yields high results, productivity, and efficiency.

Weighting over 10 Ton with a load capacity of 2,30 m<sup>3</sup>, the BF 150.10 crusher bucket is a machine capable of a production that exceeds 120 m<sup>3</sup>/h.

With an unmatched bucket opening of 1450 x 700 mm and an output adjustment from 100 to 200 mm, this machinery is essential for primary crushing in quarries and large scale operations.

## AREAS OF APPLICATION

- QUARRIES
- MINES
- DEMOLITION
- RECYCLING
- EXCAVATION

## SPECIFICATIONS

RECOMMENDED EXCAVATOR	LOAD CAPACITY	OPENING DIMENSIONS	OUTPUT SETTING	DIMENSIONS
≥ 70 Ton	2,30 m <sup>3</sup>	L 1450 H 700 mm	≥ 100 ≤ 200 mm	3560 x 2090 H 2065 mm
OIL FLOW	PRESSURE	COUNTER PRESSURE	WEIGHT	MAXIMUM PRODUCTION
380 l/min.	230 bar	10 bar	10,50 Ton	120 m <sup>3</sup> /h

## ACCESSORIES

RECOMMENDED SPARE PARTS KIT	FIX COUPLER	QUICK FEMALE COUPLER	IRON SEPARATOR	HOUR METER
BF1501015	FC1510000	-	-	804MBNF01
			DUST SUPPRESSION KIT	24 MONTHS WARRANTY
			-	WA2415010

The data provided above is not binding, as the manufacturer reserves itself the right to make improvements to its products at any time and with no advance notice. References to excavator weights are approximate and many may be subject to changes. Consider a 20% tolerance.