

CRAWLER BULLDOZER ZD160(S)-3/6



ZOOMLION



CRAWLER BULLDOZER

ZD160(S)-3/6

	Items	Units	ZD160-3/6	ZD160S-3/6
Engine	Manufacturer	/	WEICHAI	WEICHAI
	Model	/	WD10G178E25/ WP10G178E355	WD10G178E25/ WP10G178E355
	Displacement	L	9.726	9.726
	Rated Speed	r/min	1850	1850
	Rated Power	kW	131	131
	Electric Generator	/	28V、1.54kW	28V、1.54kW
	Fuel Consumption Rate	g/kW·h	≤215/191	≤215/191
	Starter Motor	/	24V、6.6kW	24V、6.6kW
Undercarriage	Width of Track Shoe	mm	510	950
	Pitch	mm	203.2	203.2
	Track Gauge	mm	1880	2300
	Length of Track On Ground	mm	2430	2935
	Ground Clearance	mm	400	444
	Number of Track Shoes (per side)	piece	37	42
Working Device	Blade Type	/	Straight tilt blade	Swamp straight tilt blade
	Width	mm	3416	4150
	Height	mm	1150	1039
	Max. Lift of Blade Above Ground	mm	1095	1052
	Max. Drop of Blade Below Ground	mm	545	450
	Blade Capacity	m ³	4.6	4.7
Dimensions and Weight	Operating Weight	kg	16610	18100
	Length (without ripper)	mm	5055	5305
	Length (with multi-shank ripper)	mm	6360	/
	Width	mm	3416	4150
	Height (to top of cab)	mm	3095	3140

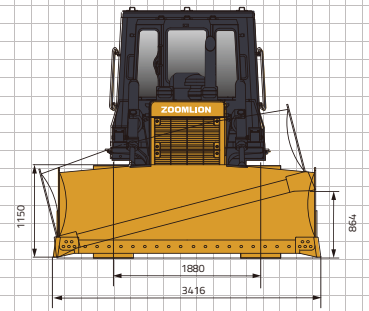
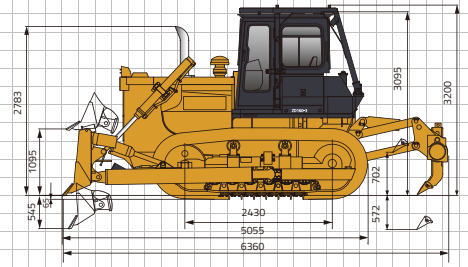

ZOOMLION

Zoomlion Heavy Industry Science & Technology Co.,Ltd.

Add: No.361, South Yinpen Road, Changsha, Hunan Province, P.R.China 410013

Email: earthmoving@zoomlion.com

Copyright©2021 Zoomlion. All rights reserved. Reproduction and copying of any part of contents is not allowed for any purposes without Zoomlion's approval. Note: Materials and specifications are subject to change without notice. Featured machines in photos may include additional equipment. See your Zoomlion dealer for available options.

