



PLUSVAREM



**VASI IDRICI PER ALTA PRESSIONE  
HIGH PRESSURE WATER TANKS**

Modello/Model: S5300461CS0CE000

**Caratteristiche tecniche - technical features**



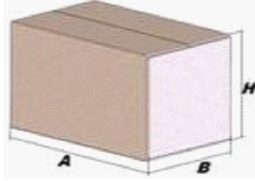

Volume Volume		<b>300 L</b>
raccordo connector		<b>1" 1/2 GAS (ISO 228/1)</b>
temperatura esercizio working temperature	<b>TS</b>	<b>-10 +99 °C</b>
pressione max. Max pressure	<b>PS</b>	<b>14 bar</b>
pressione prova test pressure	<b>PT</b>	<b>21 bar</b>
precarica precharged pressure		<b>2 bar (range 0,5-3,5 bar)</b>
Fluido Fluid		<b>Aria+acqua Air+water</b>
Ente notificato per certificazione PED Notified Body number:		<b>0948</b>
Modulo: Module:		<b>B+D</b>
N° certificato N° certificate:		<b>TIS-PED-VI-10-12-003769-4518 rev.1 + PED-0948-QSD-419-14 Rev.001</b>

**Imballo - packaging**

	A	B	H
dimesioni (mm) dimensions (mm)	1398	663	643
volume (m <sup>3</sup> ) volume (m <sup>3</sup> )	0,60		
peso (kg) weight (kg)	72,1		
q.ta per cartone q.ty for box	1		
quantità per paletta Q,y for std. pallet	6		



**Parti di ricambio - Spare parts**

	codice item	materiale material	potabilità potable	trattamento treatment	immagine image
Membrana Membrane	MB300F2P000000 00	GOMMA PER ACQUA USO ALIMENTARE / RUBBER FOR POTABLE WATER	X		
Attacco superiore Top flange	SPATT153ZN0V0 000	ACCIAIO AL CARBONIO / CARBON STEEL	X	ZINCATURA / GALVANIZED	
Dado 1/2 + guarnizione 1/2" nut gasket	SPTAP120ZN0000 00	ACCIAIO AL CARBONIO / CARBON STEEL	X	ZINCATURA / GALVANIZED	
Valvola precarica Precharge valve	ACVAL200PR000 000	OTTONE / BRASS			

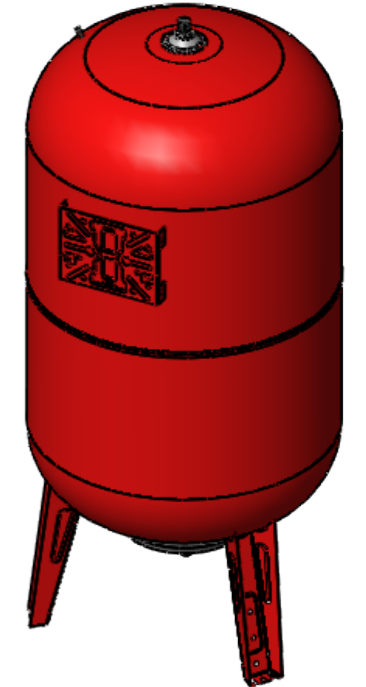
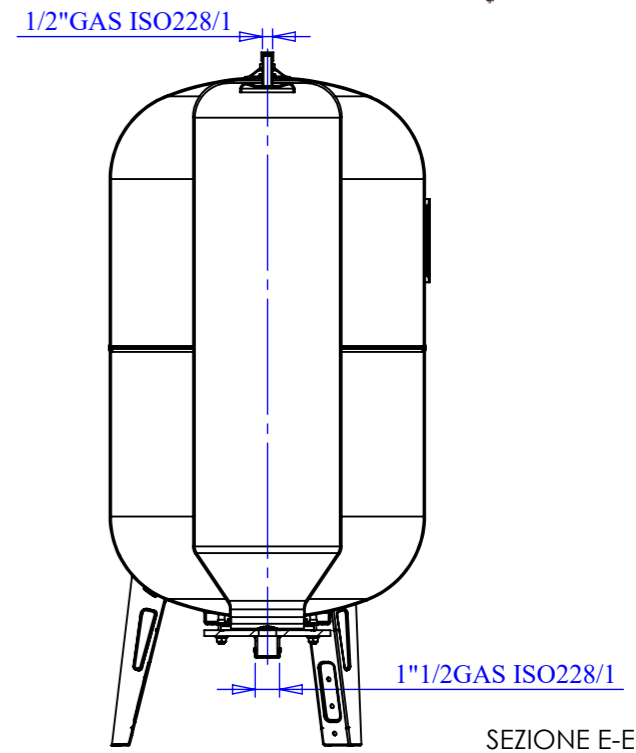
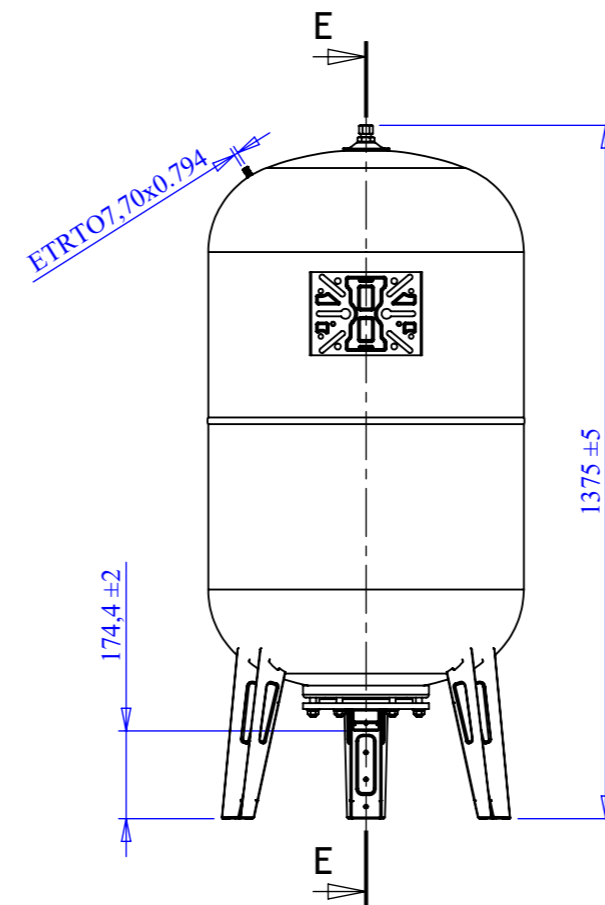
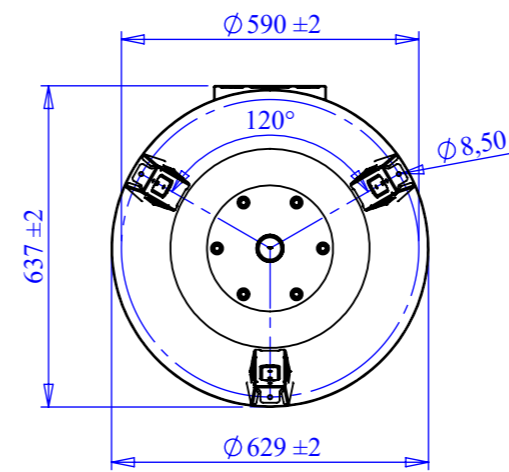

Quote senza indicazione di tolleranza: grado di precisione MEDIO, UNI EN 22768-1		LIPRO	TIPO PARTE	COLORE
SMUSSI NON QUOTATI		RUGOSITA'	FORMATO FOGLIO	FINITURA SUPERFICIALE
SCALA		1:15	A3	-
GRUPPO - MACCHINA		QUANTITA' PER GRUPPO FOGLIO	1 / 3	NOME
 via Sabbioni n° 2 - 35024 Bovolenta - Padova ITALIA e-mail:technical@varem.com Tel. 049/8840322 Fax 049/8841399		Disegnato M. Tomasin 11/05/2009 Approvato F.MAZZUCATO 16/03/2020		DATA
DESCRIZIONE				
PLUSVAREM CE L. 300 - 1"1/2 - 14 BAR				
COMMESSA	CODICE		REVISIONE	
-	S5300461CS0CE000		00	

Il presente disegno è di proprietà della **VAREM** e non può essere riprodotto ne comunicato a terzi senza ns autorizzazione scritta