

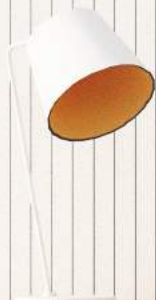















EASI-FLO SERIES

Condensate Removal Pumps
For Air Conditioners







Product Lineup

For Residential & Light Commercial

Capacity	1.0 HP	1.5 HP	2.0 HP	2.5 HP
Application	FOR RESIDENTIAL USE			
Easi-Flo II PB10245 (SP)				
Easi-Flo 22 PB20245 (SP)				
Easi-Flo 33 PF10245 (SP)				
Easi-Flo 55 PF20245 (SP)				
Easi-Flo 100 PE60245 (SP)				

For Commercial

Capacity	7.0 HP	8.0 HP	10.0 HP	12.0 HP	15.0 HP	20.0 HP
Application	FOR COMMERCIAL USE					
Easi-Flo 100 PE60245(SP)						
Easi-Flo 200 PH71245(SP)						

3.0 HP	3.5 HP	4.0 HP	5.0 HP	6.0 HP
FOR LIGHT COMMERCIAL USE				
				
				
				
				
				

The Most Complete Range of Air Conditioner Drainage Pump & Pump Accessories

Acson Malaysia is at the forefront of drainage pump technology. The complexity of installations required market leading products to best suit the application and environment. Drainage pumps are the best method for removing excess water from the units as they can be placed almost anywhere within an existing or brand new air conditioning system.

Using only the top quality materials and manufactured to the highest standard, Acson drainage pumps offer installers the flexibility and reliability for all installation support needs.

International Safety Standards Compliance

- Comply with international electrical appliances safety standards.
- UL certified fire retardant material (UL94V-0).



Product Feature



Exclusively Cater All Levels Of Needs

As a pioneer of drainage pump in Malaysia air conditioning industry, Acson Malaysia offers full range of air conditioner drainage pumps from which cover 1 - 20HP to cope with different needs and requirements.

Be it a residential, light commercial or commercial type of air conditioners, Acson drainage pump can sophisticatedly fulfill the needs of users.

Easi-Flo Drainage Pumps

Full Range Products from 1HP to 20HP



Easi-Flo II



Easi-Flo 22



Easi-Flo 33



Easi-Flo 55



Easi-Flo 100



Easi-Flo 200



Energy Saving

Energy conservation is a collective effort achieved by using energy more efficiently.

Acson drainage pumps are the perfect choice to solve your air conditioner condensate issue as they are more energy efficient while maintaining the top performance.

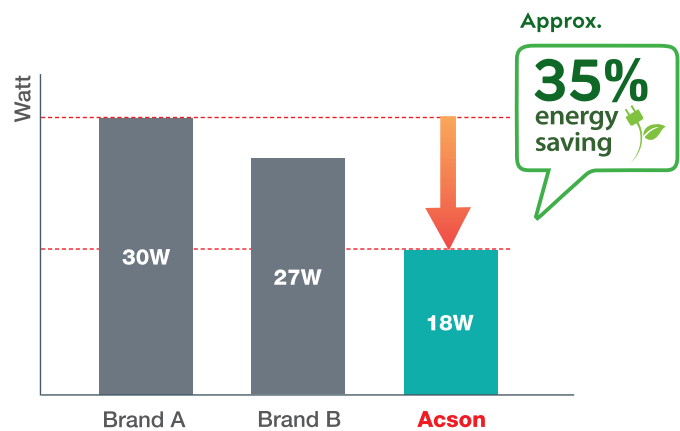

Trustworthy Service

Based on more than 30 years of service experience, Acson Malaysia has strategically developed a comprehensive service process from pre-sales supports to after-sales services. We provide professional and insightful solutions that best meet customers' needs and interests.



Specification

Model Name	Easi-Flo II	Easi-Flo 22	Easi-Flo 33	Easi-Flo 55	Easi-Flo 100	Easi Flo 200
Model Number	PB10245(SP)	PB20245(SP)	PF10245(SP)	PF20245(SP)	PE60245(SP)	PH71245(SP)
Power Rating	AC240V/ 50Hz		AC240V/ 50Hz		AC240V/ 50Hz	
Power Consumption (W)	18	18	18	14	58	68
Unit Dimension HxWxD (mm)	150 x 190 x 110		140 x 180 x 102	135 x 180 x 102	140 x 250 x 110	168 x 290 x 128
Net Weight (kg)	1.7	1.7	1.5	1.4	1.8	2.2
Pump Lift (m)	3	3	2.5	2.5	5	5.5
Max Flow Rate (Litre/min)	2	2	1.8	1.6	2.5	7
Sound Level (dB)	43	43	39	39	50	50
Tank Volume (ml)	600	600	400	400	850	1500
Drain Tube Inner Diameter (mm)	4	4	4	4	4	9.5
Drain Tube Outer Diameter (mm)	6	6	6	6	6	11.5
Max Air Conditioner Drain Pipe Diameter (mm)	25	25	20	20	20	30
Max Drain Tube Length (m)	10	10	10	10	15	15
Max Drain Tube Elevation (m)	2	2	1.5	1.5	4	4

Feature & Accessories

Model Name	Easi-Flo II	Easi-Flo 22	Easi-Flo 33	Easi-Flo 55	Easi-Flo 100	Easi-Flo 200
Float Control						
PCB with Optical Sensor	•					
Mechanical Float Switch		•	•	•	•	•
Drain Tube						
Anti Fungus PE Tube	•	•	•	•	•	
PVC Tube						•
Mechanism & Operation						
Operating Indicator	•					
Overflow Indicator	•					
Overflow Safety Switch					•	•
Thermal Protector					•	•
Temperature Fuse	•	•	•	•		
Fire Retardant Material	•	•	•	•	•	•
UL Certified Power Cord	•	•	•	•	•	•
Accessories						
Durable Metal Installation Bracket	•	•	•	•	•	
Built-in Duckbill Check Valve					•	•
Duckbill Check Valve (Optional)				•		
Anti-fungus PVC Tube (5 meter)	•	•	•	•	•	
Anti-fungus PVC Tube (10 meter)						•

Remark:

1. Installation and maintenance should be performed by qualified persons who are familiar with local code and regulation, and experienced with this type of appliance.
2. All field wiring must be installed in accordance with the national wiring regulation.
3. When the pipe length becomes too long, both the capacity and reliability drop.
4. As the number of bends increase, resistance to flow of water increases, thus lowering drainage capacity and as a result the drainage may become inefficient.
5. Always choose the shortest path and follow the recommendation as tabulated in the Installation Manual.

RESIDENTIAL & LIGHT COMMERCIAL

EASI-FLO II

In HVAC and refrigeration processes, the condensate water need to be channeled out from the building. Condensation often occurred when air passed though evaporator coil during the process of cooling.

As a pioneer in air conditioner drainage pump industry, Easi-Flo II is designed and produced for safety according to the industry standards. It is incorporated with patented Shock Absorber System that reduce the noise and vibration to the lowest level possible.

Easi-Flo II is equipped with waterproof Printed Circuit Board (PCB), Operating Indicator and Overflow Indicator for safe and precise electronic float control. Build with high impact ABS tank material, the leak-proof and rustproof design make Easi-Flo II a powerful pump to eliminate all the condensate water effortlessly.



Model Name	Easi-Flo II
Power Rating	AC240V/ 50Hz
Power Consumption	18W
Practical Pump Lift	2.5 m
Outlet Tube	ø4 × 6mm
Dimension (HxWxD)	150 x 190 x 110 mm

Product Feature



Operating LED Light (Green) and overflow LED light (Red)

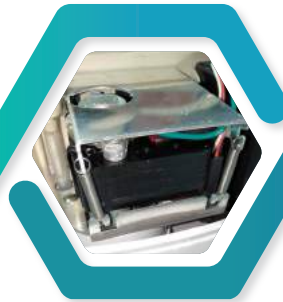

Incorporated with patented Shock Absorber System



Specially designed water outlet enable higher drainage efficiency



Water pipe positioning column at the water inlet ensuring smooth flow



Three core wire ensures electrical safety



Waterproof PCB for safe and precise electronic float control

Applications

Easi-Flo II is suitable for wall mounted split type air conditioners for residential use, as well as light commercial applications.



Accessories

<p>Standard Installation Kit consisted of durable metal mounting bracket, plastic anchors and installation screws</p>	
<p>Drain Hose (5 Meters Length)</p>	

Performance

It is advisable to install Acson drainage pump at its practical pump lift instead of maximum pump lift to prevent water overflow.

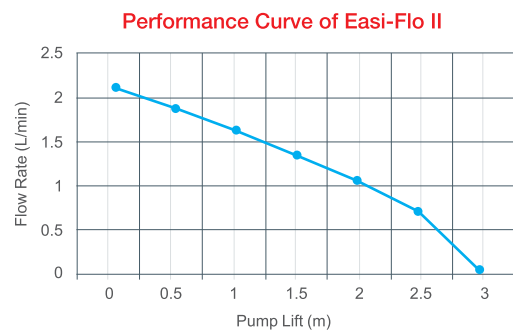

RESIDENTIAL & LIGHT COMMERCIAL

EASI-FLO 22

EASI-FLO 33

EASI-FLO 55

Perfect for residential as well as commercial use, Easi-Flo 22, Easi-Flo 33 and Easi-Flo 55 would be your best choice to channel the condensate water away from air conditioners in your home.

With the improved impeller design, both drainage efficiency and energy efficiency is enhanced. In other words, Easi-Flo 22, Easi-Flo 33 and Easi-Flo 55 consume even lower energy than others and save your electricity bills. The Underwriters Laboratories (UL) certified power cord and built-in temperature fuse ensure the reliability and safety of users.

Easi-Flo 55 is equipped with a removable Duckbill Check Valve option to prevent the water from flowing back into the tank in the event that the outlet line is at a higher level than the tank.

Thus it provides a hassle free condensate removal experience.



Easi-Flo 22



Easi-Flo 33



Easi-Flo 55

Model Name	Easi-Flo 22	Easi-Flo 33	Easi-Flo 55
Power Rating	AC240V/ 50Hz		
Power Consumption	18W	18W	14W
Practical Pump Lift	2.5 m	2.0 m	2.0 m
Outlet Tube	ø4x6mm	ø4x6mm	ø4x6mm
Dimension (HxWxD)	150 x 190 x 110 mm	140 x 180 x 102 mm	135 x 180 x 102 mm



Product Feature

- Improved impeller design that boost the drainage efficiency.
- Built-in temperature fuse ensure the safety of users.
- Durable metal installation bracket provides strongest support to the unit.
- Three core wire provides electrical safety.

Applications

Easi-Flo 22 is suitable for both residential and light commercial applications.

Easi-Flo 33 and 55 are perfect for wall mounted split type air conditioners.





Easi-Flo 22



Easi-Flo 33

Accessories

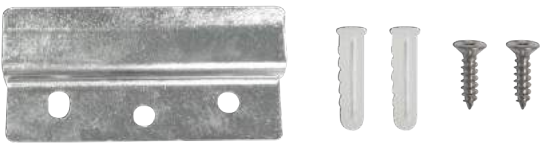
*Only applicable for Easi-Flo 55.

Standard Installation Kit consisted of durable metal mounting bracket, plastic anchors and installation screws	Drain Hose (5 Meters Length)	Duckbill Check Valve*
		 <p data-bbox="1209 1395 1433 1417">To prevent water backflow</p>

Performance

It is advisable to install Acson drainage pump at its practical pump lift instead of maximum pump lift to prevent water overflow.

Performance Curve of Easi-Flo 22

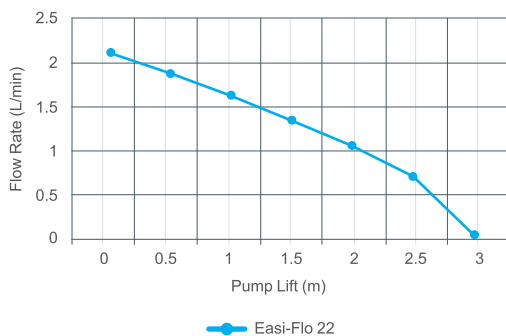

Performance Curve of Easi-Flo 33 & Easi-Flo 55

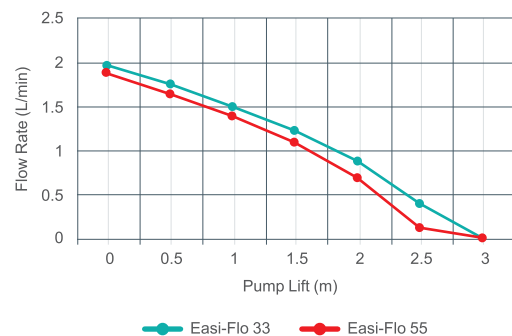

COMMERCIAL

EASI-FLO 100

EASI-FLO 200

Easi-Flo 100 and Easi-Flo 200 are designed for commercial use to suit with the heavy-duty usage of industrial environment.

Equipped with Thermal Overload protection, the pump motor will be automatically shut down in the event of overheating, hence protecting the pump from damage or fire hazard. A Overflow Safety Switch is good as an output that can be used to shut down the air conditioners to prevent further damage to the system.

Made with with fire retardant material and Underwriters Laboratories (UL) certified power cord, Easi-Flo 100 and Easi-Flo 200 ensure the reliability and safety of users.



Easi-Flo 100



Easi-Flo 200

Model Name	Easi-Flo 100	Easi-Flo 200
Power Rating	AC240V/ 50Hz	
Power Consumption	58W	68W
Maximum Pump Lift	5.0 m	5.5 m
Outlet Tube	ø4x6mm	ø9.5x11.5mm
Dimension (HxWxD)	140 x 250 x 110 mm	168 x 290 x 128 mm



Product Feature

- Wide range of applications including residential and commercial type of air conditioners.
- Easy installation with multiple inlet holes available.
- Three core wire provides electrical safety.
- Built-in Overflow Safety Switch and Duckbill Check Valve ensure one way water flow and prevent backflow operations.
- Built-in thermal protector to prevent the motor from overheating.

Applications

Easi-Flo 100 and Easi-Flo 200 are perfect for both residential and light commercial applications. For example, wall mounted, floor standing, ceiling cassette, ceiling concealed and ceiling exposed units. They are also compatible with larger commercial type air conditioners such as ducted blower and fan coil units.



Wall Mounted



Ceiling Concealed





Floor Standing



Ceiling Exposed

Accessories

*Only applicable for Easi-Flo 100.

5 Meters Length Drain Hose (For Easi-Flo 100) 10 Meters Length Drain Hose (For Easi-Flo 200)	Mounting Bracket (Optional)*	Silicon Connector & Fastener*
		 <p data-bbox="970 1603 1433 1630">To tighten the drain hose and ensure smooth water flow.</p>

Performance

It is advisable to install Acson drainage pump at its practical pump lift instead of maximum pump lift to prevent water overflow.

Performance Curve of Easi-Flo 100 & Easi-Flo 200

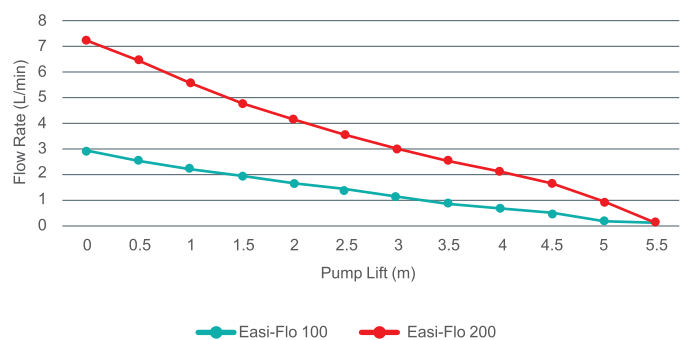



ACSON MALAYSIA SALES & SERVICE SDN.BHD. (129688-D)

a member of DAIKIN group

Lot 4, Lorong 19/1A, Seksyen 19, 46300 Petaling Jaya,
Selangor Darul Ehsan, MALAYSIA.

Tel : +603 7964 8200 Sales Fax : +603 7956 9909

Service Fax : +603 7956 9907 Acson Careline : 1300 22 3344

Penang	: +604-5377 176	Pahang	: +609-5178 696
Perak	: +605-3129 828	Kelantan	: +609-7405 233
Melaka	: +606-2926 196	Sarawak	: +6082-344 128
Johor	: +607-3551 599	Sabah	: +6088-420 205

www.acson.com.my

Authorized Dealer :

Products manufactured in an ISO certified facility.
This document contains the most current product information as of this printing.
For the most up-to-date product information, please logon to www.acson.com.my